

## All in one

### DPF/SCR with integrated Silencer

#### benefits

- **Easy to install** within engine or genset contours
- **Single source** exhaust engineering and delivery
- **Easy integration** on top of genset
- **Highest ash tolerance** to allow long service intervals
- **Save costs on urea** thanks to the **IMO Tier II/IMO Tier III switchable feature**
- **Short lead time** – less engineering alignment
- **Optimized** back pressure
- **Performance guaranteed**

#### technical description

- **35db(A) insertion loss** as standard
- Active regenerated DPF **reduces black carbon emissions to more than 98%**
- **Robust full flow regeneration burner**
- **Single service side**

*hug*engineering.

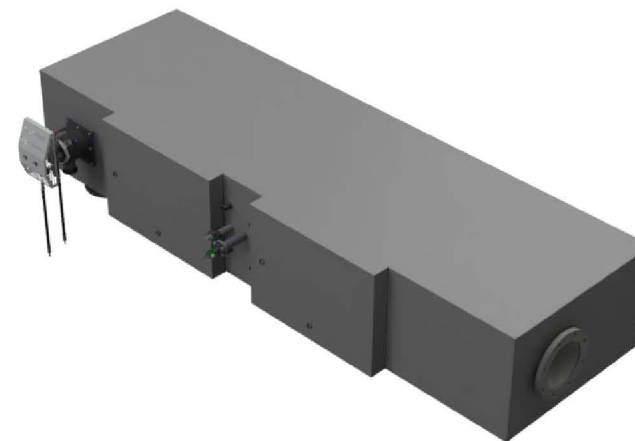

#### applications

- **Displacement Yachts**
- **Semi displacement Yachts**
- **Port authority vessels**
- **Gensets up to 500 kW**

innovation

RFQ ready

In production

#### certifications



Lloyd's  
Register Type approval

Other type approvals on request