

Generic SCR

Meet IMO III with the highest flexibility

benefits

- IMO TIER III certified product - adaptable to TIER II engines
- Reliable, robust & flexible, switchable outside ECA Zone
- Integrated DPF/silencers available
- Handles DEF concentrations from 32.5% to 40%
- Global Service
- Emission certification available for all major engine brands

technical description

- **Fully optimized system** and highest flexibility by modular setup and full engineering control of all components. Apparatus, Catalyst & Steelwork are all **made in house**
- **Air assisted DEF injection for maximum robustness**
- **CFD internal studies to ensure:** homogeneous distribution, NH3 slip control, deposit proven design for any systems arrangement
- **Full customization to fit in any installation space**

*hug*engineering.

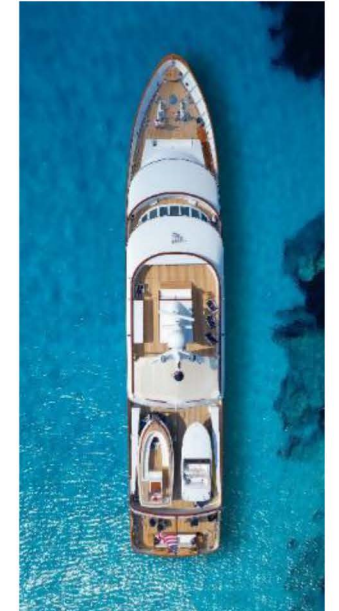
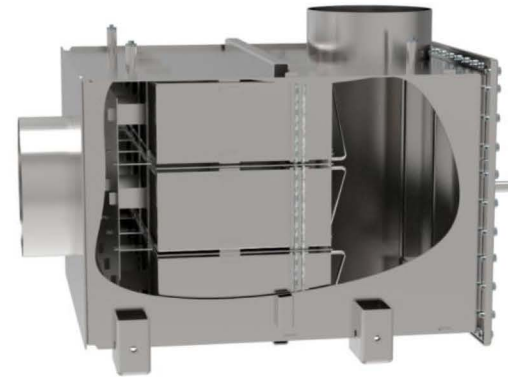

applications

- Yachts
- Inland waterway vessels
- Work boats
- Ferries

Innovation

RFQ ready

In production

certification



Compliant

Type approved
by members of

